

3M ESPE

Vinyl Polysiloxane
Impression Material

Technical Product Profile

Express

Penta™ Putty & Ultra-Light Body

Table of Contents

Introduction	5
History of Precision Impression Materials	6
Development of Automatic Application Systems for 3M ESPE Impression Materials ..	6
Motivation	7
Indications	9
Overview of Material Characteristics	10
Technical Overview	17
Composition	20
Comparison of Handmix/Automix procedures	21
3M ESPE Internal Application Test	22
Instructions for Use	27
Express™ Penta™ Putty – Step-by-Step	31
Frequently Asked Questions (FAQ's)	32
Clinical Case Study Documentation	37
Summary	41
Bibliography	42
Technical Data	43

Introduction

20 years ago Express™ Vinyl Polysiloxane Impression Material from 3M ESPE brought about lasting changes in impressioning with the launch of the world's first light-bodied impression material that could be mixed automatically in the Garant™ Dispenser. With Express™ Penta™ Putty and Express™ Ultra-Light Body Vinyl Polysiloxane Impression Materials, produced by 3M ESPE, Express Impression Material is once again setting the standard for the future thanks to a perfectly adapted combination of materials for the two-step putty wash technique and the one-step tray wash technique. Both materials are suitable for all types of precision impressions, and in particular for crown, bridge, inlay and onlay preparations. They stand for high precision when taking impressions while simultaneously offering the convenience of modern technology.

Express Penta Putty is the first 3M ESPE addition-cured silicone with a real “putty” consistency (ISO 4823 type 0) that is mixed automatically in the Pentamix™ 2 Mixing Unit. It thus represents an extension of range of Penta™ impression products in the very heavy-bodied, putty impression materials segment. This now allows dentists who prefer putty type silicones for precision impressions to benefit from the advantages of the Pentamix System. Until now these materials have typically been mixed by hand. Express Penta Putty offers the characteristics appreciated in a putty silicone such as high resistance when inserting the tray and the option of shaping the mixed paste in the tray with the fingers. The impression material has been specifically optimized for the requirements of the two-step putty wash technique and is characterized by high final rigidity and very easy carve of the first - initial - impression. These characteristics can now also be combined with the benefits of automatic mixing, such as a homogeneous void-free mix, consistent mixing quality as well as simple and clean handling.

Express Ultra-Light Body Impression Material is an ultra-light-bodied, addition-cured hydrophilic silicone (ISO 4823 type 3) supplied in the Garant™ Cartridge. It has been specially developed for use in combination with Express Penta Putty in the two-step putty wash technique. Express Ultra-Light Body is characterized by brilliant flow properties and high structural viscosity, known also as thixotropic behavior. This means that the Impression Material stays at the tooth upon syringing while flowing in extremely thin layers in second impressions when under pressure. Thanks to its hydrophilicity, Express Ultra-Light Body also provides brilliant results in moist environments. The very good tear strength achieved by the use of new monomers with good curing properties mini-mizes the risk of the impression material tearing, e.g. in the interdental areas or in the sulcus.

Express Penta Putty Vinyl Polysiloxane Impression Materials can also be used in the one-step tray wash technique with Express Ultra-Light Body Impression Materials and existing 3M ESPE light-bodied materials, e.g. Imprint™ II, Express or Dimension™ Garant™ Vinyl Polysiloxane Impression Materials. In this case it offers quick setting behavior and is designed for dentists preferring a very heavy-bodied tray material. Now, of course complemented by all advantages of automatic mixing.

History of Precision Impression Materials

The first impression methods using wax, plaster and zinc oxide eugenol pastes were succeeded by true precision impressions some 75 years ago (1925) with the introduction of hydrocolloids (see Fig. 1). Today hydrocolloids are still used to some extent when taking precision impressions although their popularity is in decline. On the other hand, the polysulphides, which were introduced somewhat later, have almost lost their importance for precision impressions nowadays.

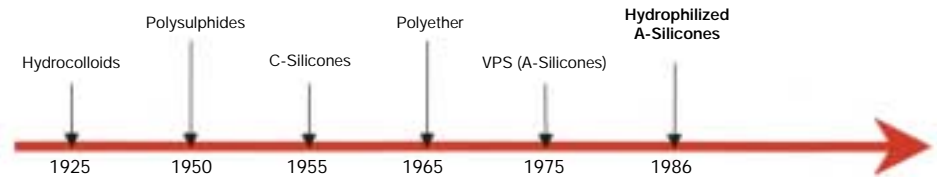

Fig. 1: History of precision impression materials

In the mid 1950s a class of material that was not originally intended for intraoral use made its appearance in the world of dentistry: C-silicones (condensation-cured). The main disadvantages of these products were, and still are, their intrinsic shrinkage as condensation-curing involves the release of a by-product and their hydrophobicity.

A decade later in 1965 polyether was introduced by ESPE. This is an addition-cured hydrophilic impression material that is vastly superior to hydrocolloids and C-silicones in terms of mechanical values (e.g. tear strength), involves virtually no shrinkage as addition-curing does not release any by-products and is well established due to the first-class hydrophilicity.

Another 10 years later in 1975, the first A-silicones (addition-cured) were used as impression materials. However, they were still hydrophobic due to their chemical nature. It was only in 1986 that it became possible to reduce the hydrophobicity intrinsic to the material's molecular structure. With the addition of surfactants, the hydrophilicity of the mixed material increases in the course of time.

Development of Automatic Application Systems for 3M ESPE Impression Materials

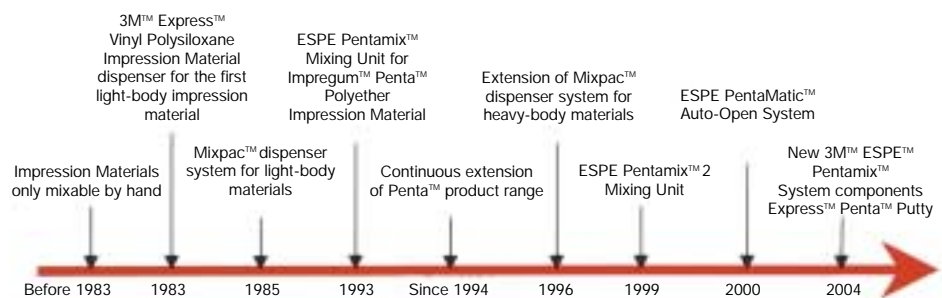

Fig. 2: Development of automatic application systems for 3M ESPE Impression Materials

The world's first application system for the automatic mixing of impression materials was launched by 3M (today 3M ESPE) in 1983 in the form of the 3M[™] Express[™] Dispenser for the first Express[™] light-body material. Two years later in 1985, this was followed by the Mixpac[™] dispenser system (produced by ConProTec, Inc.), which provided for the automatic mixing of other light-body materials.

With the launch of the Pentamix™ System in 1993, ESPE set a further milestone in the history of automatic mixing systems, bringing about a lasting change in the impression procedure at dental office. The development of Penta™ products started with Impregum™ Penta™ Polyether Impression Material. In the following years the Penta product range was continuously extended.

In 1996 the Mixpac™ Dispenser System was extended to include heavy-body materials. 1999 saw the introduction of the 3M™ ESPE™ Pentamix™ 2 Mixing Unit, catering for the wish of many practitioners for a faster unit. A year later in 2000, this was followed by the launch of the PentaMatic™ System, an automatic opening mechanism for the foil bags.

The introduction of three new Pentamix System components in 2004 has allowed the Penta product range to be extended to include the putty material segment. This means that an Express Penta putty material is now also available as a foil bag version for the first time.

Motivation

The automatic mixing of impression materials with the Pentamix™ Mixing Unit has, in the meanwhile, become a standard in many dental offices, not lastly due to the undeniable benefits this offers. Such benefits include a homogeneous void-free mix, uniform mixing quality as well as simple and clean handling (cp. also Technical Product Profile for Pentamix, available from 3M ESPE).

Despite the meanwhile very extensive 3M ESPE product portfolio for Penta™ Impression Materials (Fig. 3), to date it still has not been possible for a large number of dentists to take advantage of the benefits of the Pentamix System. These are dentists who prefer to use putty silicones for taking precision impressions. Due to their very high viscosity levels, these materials have been typically mixed by hand, incurring the associated disadvantages such as non-homogeneity and the presence of voids in the mix.

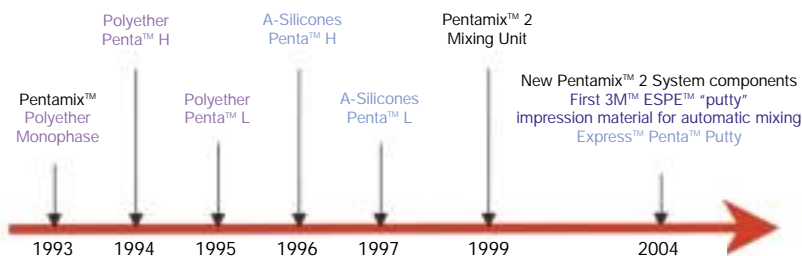

Fig. 3: Launch of 3M™ ESPE™ Pentamix™ precision Impression Materials (by classes of material and viscosities). The Penta™ product line was first launched in 1993 with Impregum™ Penta™ Impression Material, the first medium-bodied polyether material. In 1996 the first heavy-bodied Penta VPS was introduced with the name Dimension™ Penta™ H (H stands for heavy-body Impression Material). This was followed one year later by Dimension Penta L (L stands for light-body Impression Material), the first light-bodied Penta VPS Impression Material. Another 7 years later the first Penta Putty Impression Material from 3M ESPE made its appearance in the form of Express™ Penta™ Putty.

In particular dentists value putty silicones because of their high resistance on insertion of the tray and the resulting high pressure that forces the low viscosity wash material deep into the sulcus. In addition, the mixed material can be distributed and shaped in the impression tray with the finger. With Express™ Penta™ Putty Vinyl Polysiloxane Impression Material the objective is to also offer this group of dentists a suitable impression material with putty characteristics that can be automatically mixed in the Pentamix Mixing Unit.

The development of Express™ Penta™ Putty Vinyl Polysiloxane Impression Material represented a major challenge, not just for the chemists but also the engineers at 3M ESPE. While the impression material was being developed, they brought in their know-how to jointly design the innovative new Pentamix™ System components (see chapter Technical Overview). Additionally, it is by combining a new chemical composition (see section Composition) with new Pentamix System components that it has become possible for the first time to use such highly viscous pastes in the Pentamix Mixing Unit.

The aim was to optimize the characteristics profile of Express Penta Putty Vinyl Polysiloxane Impression Material specifically for the two-step putty wash technique (good carving properties, high Shore hardness). At the same time, the dentist was to be provided with a very low viscosity wash material (Express Ultra-Light Body Vinyl Polysiloxane Impression Material) specially adapted for Express Penta Putty Vinyl Polysiloxane Impression Material. During the development of Express Ultra-Light Body special importance was given to characteristics such as high hydrophilicity, excellent flow properties and high tear strength.

The following sections show how with Express Penta Putty and Express Ultra-Light Body Impression Material, 3M ESPE has managed to come up with a combination of materials, based on vinyl polysiloxane impression materials (VPS), which are perfectly adapted for use together in the two-step putty wash technique. This combination stands for very high precision and detail reproduction.

Express Penta Putty Vinyl Polysiloxane Impression Material can also be used in the one-step tray wash technique with Express Ultra-Light Body Vinyl Polysiloxane Impression Material and existing 3M ESPE light-bodied materials, e.g. Imprint™ II, Express or Dimension™ Garant™ Vinyl Polysiloxane Impression Material. In this case it offers quick setting behavior and is designed for dentists preferring a very heavy-bodied tray material. Now, of course complemented by all advantages of automatic mixing.

Indications

All precision impressions (e.g. of crown, bridge, inlay, and onlay preparations).

Express™ Penta™ Putty and Express™ Ultra-Light Body Vinyl Polysiloxane Impression Materials can be used to produce all types of precision impressions with the two-step putty wash technique. These materials are ideally suited in particular for crown, bridge, inlay and onlay preparations.

For precision impressions using the one-step tray wash technique Express Penta Putty Vinyl Polysiloxane Impression Materials can be combined with Express Ultra-Light Body Vinyl Polysiloxane Impression Materials or with other 3M ESPE syringing materials based on VPS (also see FAQ's Section). Here too the materials are particularly suitable when taking impressions for crown, bridge, inlay and onlay preparations. Due to the short setting time, the use in one or two unit cases is especially recommended in this technique.

Overview of Material Characteristics

Chemical principles and discussion

The objective for the development of Express™ Penta™ Putty and Express™ Ultra-Light Body Vinyl Polysiloxane Impression Materials was, on the one hand, to create a new combination of impression materials which unite the benefits of the Pentamix™ Mixing Unit with the high consistency of putty materials. On the other hand, the aim was to provide a perfectly adapted wash material with greatly improved flow properties, bringing together the benefits of high structural viscosity and super flow properties with a high tear strength and hydrophilicity.

Express Penta Putty – a real putty material

Chemical matrix

Express Penta Putty is a purely addition-cured silicone (VPS) consisting of

- A combination of vinyl polysiloxanes of varying chain lengths
- A combination of different hydrogen polysiloxanes
- Platinum catalyst
- A combination of fillers on a silicon dioxide basis
- A combination of plasticizers

The mixing of a putty consistency in the Pentamix Mixing Unit requires a combination of reactive polysiloxanes and fillers that is new to putties. This is an innovative way to rheologically enable the use of such high-viscosity pastes in the Pentamix, without having to forfeit any of the customary putty characteristics. The innovative polymer combinations reduce the forces on the Pentamix Mixing Unit. From the customer's viewpoint, however, the usual high putty consistency is retained. This has been confirmed in a study using newly designed test apparatus which measures the resistance presented by a mixed paste to penetration by a test specimen. Here it was demonstrated that although it can be used in the Pentamix Mixing Unit, Express Penta Putty provides dentists with the usual feel on insertion of the impression tray that is so characteristic of putties.

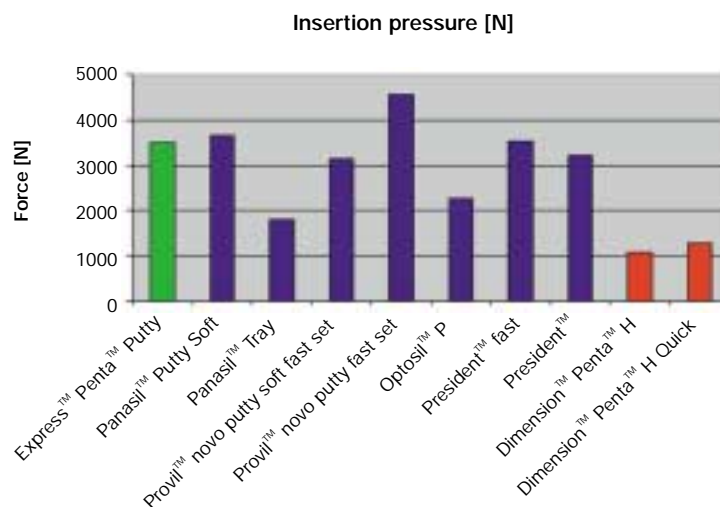

Fig. 4: Insertion resistance of various impression materials (mainly putty, red colored columns; heavy bodied materials as comparison). Source: I. Wagner et al, Insertion forces of conventional and new automixed putty impression materials, Joint Meeting of the Continental European, Israeli and Scandinavian Divisions of the IADR (August 25 – 28, 2004, Istanbul, # 140).

Long-chain vinyl polysiloxanes increase the viscosity and result in the high putty consistency of Express™ Penta™ Putty Vinyl Polysiloxane Impression Material. The addition of short-chain vinyl polysiloxanes on the other hand leads to very high final rigidity and thus a good carving of the impression material as well as fast intraoral setting.

The newly designed Penta™ Mixing Tips red for the Pentamix™ Mixing Unit also ensure a homogeneous mixing quality despite a high paste viscosity. This results in a mixing quality which is largely free from streaks and voids in a manner that is typical of materials mixed in the Pentamix. The following figure compares the cut surfaces of Express Penta Putty (test specimen on left) and a hand-kneaded specimen of Express STD Putty (test specimen on right).



Fig. 5: Mixing quality of Express™ Penta™ Putty and Express™ STD Putty

Setting reaction

The setting reaction which cures the material involves platinum-catalyzed hydrosilylation. Here hydrogen polysiloxanes are added to the double bonds of vinyl polysiloxanes under the catalytic influence of traces of a platinum compound in the ppm range.

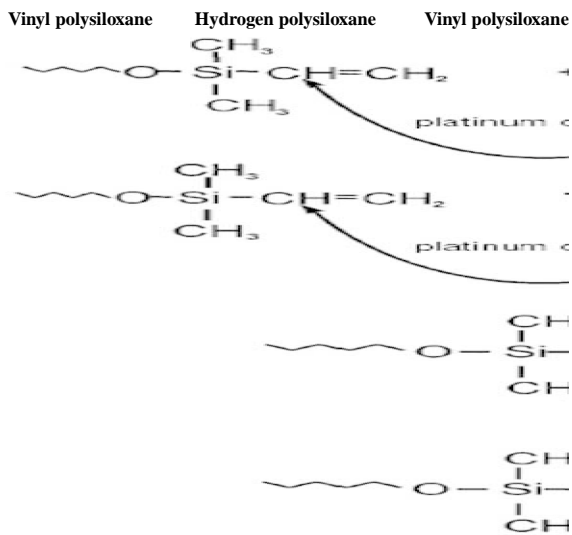

Fig. 6: Diagram of the setting reaction of addition-cured silicones

In chemical terms this reaction is purely an addition reaction in which no by-products whatsoever are released. As a result there are no volatile by-products to cause shrinkage of the elastomer, something that is seen for example in the case of condensation-cured silicones. The high dimensional stability of these VPS is one benefit of such materials.

Every setting reaction is susceptible to fluctuations in dosing, i.e. unintentional variations in the ratios between the base and catalyst. In practice this may often result in major changes in the setting time. Such effects are largely eliminated by the automatic dispensing of Express™ Penta™ Putty Impression Material in a constant volume ratio. Consistent dosing of the base paste and catalyst enables uniform setting behavior over the entire foil bag.

The following figure shows the influence of overdosing / underdosing of the catalyst on the setting time of the mixed material in the case of a condensation-cured hand-kneadable putty silicone. As one can see in Fig. 7, underdosing by 25% doubles the setting time.

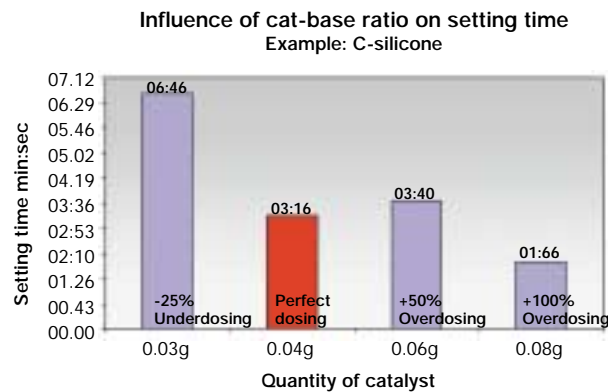

Fig. 7: Effect of overdosing / underdosing of catalyst on a standard condensation-cured putty silicone (0.04 g = exact proportion)

Comparison of material properties of Express™ Penta™ Putty Vinyl Polysiloxane Impression Material with different putty impression materials

Properties*	Express™ Penta™ Putty	Optosil™ Comfort	Express™ STD Putty
Consistency ¹	34 mm	18 mm	31 mm
Shore hardness ²	75	59	66
Elastic recovery after deformation ¹	99.5 %	98.6 %	98.9 %
Deformation under pressure ¹	1.7 %	1.7 %	1.6 %
Working time ¹	1:30 min:sec	1:00 min:sec	1:50 min:sec
Intraoral setting time	2:30 min:sec	4:00 min:sec**	5:00 min:sec

* 3M ESPE laboratory data

** Values according to instructions for use

¹ Measured according to ISO 4823

² Measured according to DIN 53505, measuring time 15 min after mixing

Note: The data do not represent ranges of values but are individual values, each relating to a specific production batch.

Summary of the benefits of Express™ Penta™ Putty Impression Material

Material properties	Penta™ components
High dimensional stability of impressions, with all addition-cured silicone impression materials	Constant and homogeneous mixing quality as well as absence of air voids
Easy carving due to high shore A hardness thanks to the new polymer combination	"Kneading" no longer required
Malleability of mixed impression material in tray using finger	Hygiene and cleanliness of mixing process
Customary putty-like insertion resistance	Accurate proportioning of precise quantity of material for tray
Fast intraoral setting due to highly reactive - polymers	Long-term storage of pastes due to hermetic air seal in extremely airtight foil bags

Express™ Ultra-Light Body

Express Ultra-Light Body is also an addition-cured silicone that is cured through hydrosilylation. The special characteristics of this material have not been solely achieved by means of optimization but additionally through the development of a new network former. This substance, which in chemical terms belongs to the class of siloxane resin-free unsaturated carbosilanes, is new to addition-cured silicone impression materials.

Reactive system

In addition to the conventional components of an addition-cured silicone, Express Ultra-Light Body Impression Material also contains reactive carbosilane crosslinking agents that modify the network produced on setting:

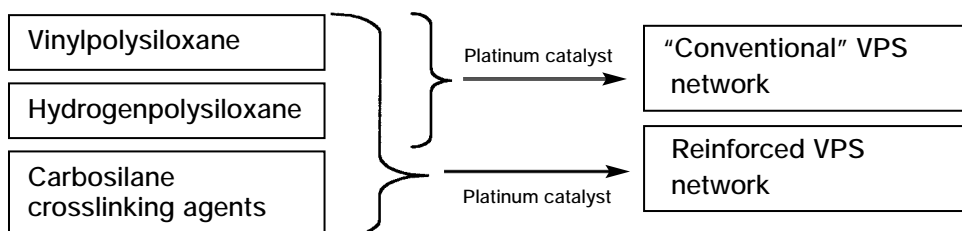

The incorporation of carbosilanes in the polymer network results in a chemical matrix with an increased crosslinking density. This increase in the crosslinking density improves the mechanical characteristics of the elastomer produced and can be seen in the greatly increased tear strength of the cured impression.

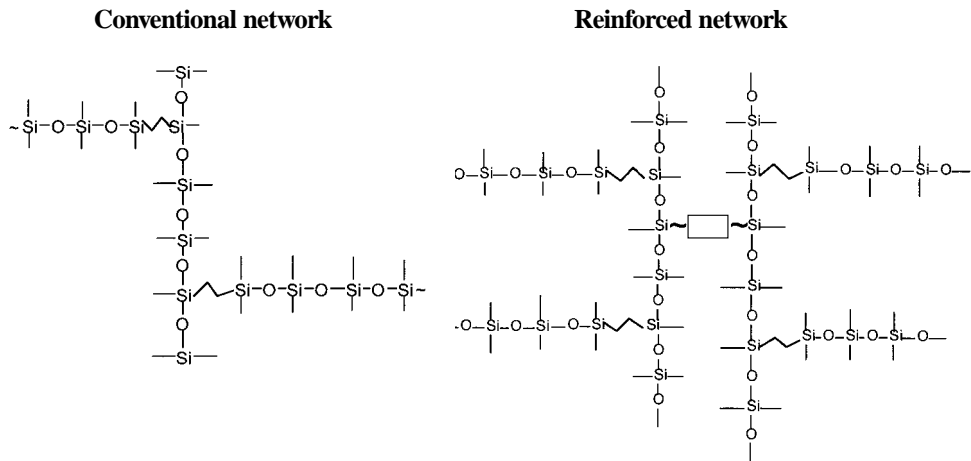

Fig. 8: Comparison in network density of a conventional and reinforced VPS network

Flow properties – clinically relevant characteristic

In comparison with many other low-consistency impression materials there has been a reduction in the proportion of fillers in Express™ Ultra-Light Body Vinyl Polysiloxane Impression Material. This basically leads to decreased viscosity, thus facilitating the flow on fine structures. This results in the very high precision and good detail production offered by this material. Due to the reduced consistency, the product nevertheless does not drip off the teeth or slump which is a huge clinical advantage.

These clinically relevant characteristics result in a very fine flow of the material, for example with the two-step impression technique. This is demonstrated by the characteristically thin layers of Express Ultra-Light Body in impressions made with the two-step putty wash technique.

Hydrophilicity and tear strength – clinically relevant features

The wettability of the material by moisture is achieved by adding hydrophilizing agents (surfactants). In the case of Express Ultra-Light Body special substances belonging to the polyether siloxane class are used. They are made up of hydrophobic silicone and hydrophilic polyether.

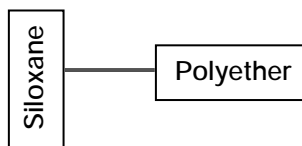

Fig. 9: Diagram of the structure of a standard hydrophilizing agent (surfactant)

The ratio between the two components is coordinated to achieve an optimum effect. This means for example, that a drop of water on the surface of Express Ultra-Light Body will spread much faster than with many other materials. The reason for this is the ideal ratio between the silicone and polyether components, resulting in highly effective wetting with the drop of water.

However, the addition of hydrophilizing agents frequently has an adverse effect in terms of the strength of the elastomer after the impression material has set. This is due to the fact that typical hydrophilizing agents do not carry reactive groups, either on the polyether or the siloxane component, which are capable of taking part in the setting reaction. This means that the molecules of the hydrophilizing agent remain in the elastomer network as plasticizers, often reducing the hardness and the tear strength of the impression material. This adverse effect may be all the more pronounced the greater the hydrophilicity of the impression material, i.e. the more hydrophilizing agents that are added for example.

It is possible to efficiently counteract this effect by reinforcing the network through the influence of the carbosilane crosslinking agent. The increased crosslinking density of Express™ Ultra-Light Body Impression Material compensates for the plasticizing effect of the hydrophilizing agent and simultaneously allows the hydrophilicity and strength characteristics of the set elastomer to be optimized. The following study shows that, for a number of conventional hydrophilized silicone impression materials with a low consistency, there is a decrease in the tear strength of the elastomer, with this decrease increasing the hydrophilicity of the material, i.e. the lower the contact angle of a drop of water on the specimen. (Source: Tear strength and contact angle of VPS impression materials, J. Zech et al., Joint Meeting of the Continental European, Israeli and Scandinavian Divisions of the IADR (August 25 – 28, 2004, Istanbul, # 139).

Material	Express™ Light Regular Set	Provil™ Novo Light	Panasil™ Contact Plus	Express™ Ultra-Light Body
Contact angle ^a	65°	78°	105°	42°
Tear strength ^b	2.4 MPa	2.6 MPa	3.1 MPa	3.0-4.4 MPa

^a Measured 10 sec after the application of a drop of water to a specimen, 1 h after mixing

^b Measured 10 h after mixing

Only Express Ultra-Light Body simultaneously showed excellent hydrophilicity and maximum tear strength due to its reinforced network in this comparison.

From the clinical relevance point of view, it is very important to study tear strength already at the time of mouth removal. This is the time when it counts whether the impression material tears off, especially in thin subgingival layers or not. Therefore the tear strength was studied already after 2:30 min at 36°C. The results are shown in the following figure.

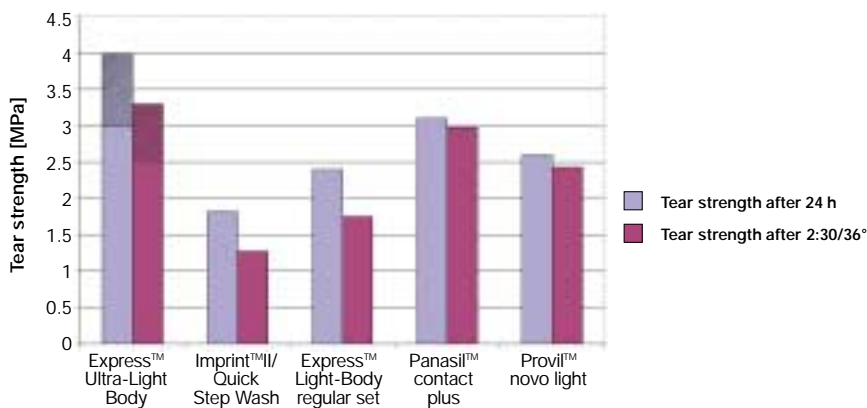

Fig. 10: The results indicate that Express™ Ultra-Light Body shows top-of-the-line tear strengths values. Therefore no tearing is expected even in the very fine structures and areas of the material.

Note: The hatched areas represent ranges of values relating to different production batches.

Comparison between material properties of Express™ Ultra-Light Body Vinyl Polysiloxane Impression Material with different wash materials

Properties*	Express™ Ultra-Light Body	Xantopren™ Blau	Express™ Light Regular Set
Consistency ¹	45 mm	42 mm	41 mm
Shore A hardness ²	53	34****	47
Recovery from deformation ¹	99.8 %	99.8 %	99.8 %
Strain in compression ¹	4.1 %	5.3 %	2.9 %
Working time ¹	1:30 min:sec	1:30 min:sec**	1:30 min:sec**
Intraoral setting time	2:30 min:sec	4:00 min:sec**	4:00 min:sec***
Margin flow properties = "shark fin" test (1 mm gap width)	18 mm	18 mm	16 mm
Contact angle after 10 sec	42°	98°	63°
Linear dimensional change ¹	0.3 %	0.7 %	0.3 %

* 3M ESPE laboratory data

** Values according to instructions for use

*** Intraoral setting time

**** Proportioning by weight

¹ Measured according to ISO 4823

² Measured according to DIN 53505, measuring time 15 min after mixing

Note: The data do not represent ranges of values but are individual values, each relating to a specific production batch.

Technical Overview

Three new Pentamix™ System components for Express™ Penta™ Putty Vinyl Polysiloxane Impression Material

The objective of providing with Express Penta Putty a real putty material for automatic mixing in the Pentamix System represented a major challenge, not just for the chemists at 3M ESPE but also for its engineers.

Until now it has not been possible to dispense real putty materials in the Pentamix System due to their characteristic high viscosity. The forces necessary to dispense these pastes far exceed the maximum dispensing force offered by the Pentamix 2 System. By using larger cross-sections for the foil bag openings and a greater free flow-through area in the Penta mixing tip, the engineers at 3M ESPE have now managed to strongly reduce the dispensing forces for conveying Express Penta Putty (Fig.11), thus releasing it for the Pentamix 2 System easily.

Fig. 11 also shows the reduction in force for dispensing pastes with both new Pentamix 2 System components (new red Penta™ Mixing Tip and new foil bag front caps) in comparison with the current components, with the example of Impregum™ Penta™ H DuoSoft Polyether Impression Material. This reduction is 51.6%.

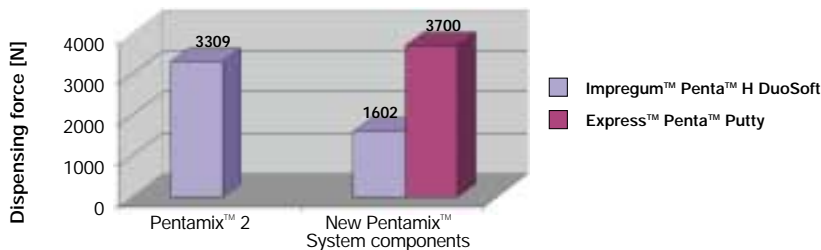

Fig. 11: Dispensing force for conveying Express™ Penta™ Putty with the new Pentamix™ System components. The diagram also compares the dispensing forces between the new Pentamix System components and the current components, e.g. Impregum™ Penta™ H DuoSoft.

In addition, the Penta Cartridge has been optimized and is equipped with steel inner tubes sheathed in plastic. This means breakage of the cartridge is practically ruled out. It is available in the standard shade – grey – with the lever in the product shade. In addition, this new combination of materials has also greatly increased the resistance to acids and solvents (e.g. aggressive cleaning agents).

Thanks to these three new system components it is now not only possible to offer customers a real putty material for automatic mixing in the Pentamix Mixing Unit but to also guarantee maximum reliability and convenience when using the Pentamix System.

Photographs of the three new Pentamix™ System components

- New: Penta™ Mixing Tip red



Fig. 12: The new Penta™ Mixing Tip Red reduces the dispensing forces for conveying the paste in the Pentamix™ Mixing Unit by up to 51.6% – as shown in Fig. 11 with Impregum™ Penta™ H Duosoft Polyether Impression Material – in comparison with the previous white Penta Mixing Tip.

- New: reinforced foil bag cartridge caps in product shade

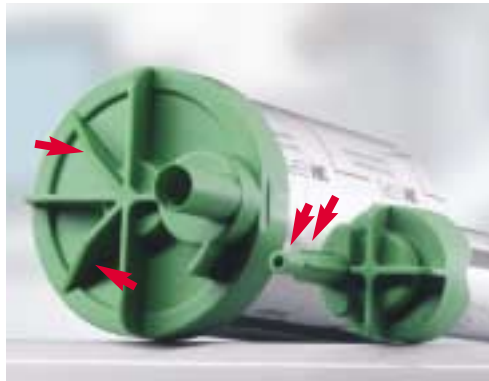

Fig. 13: New reinforced front caps of the foil bags in the product shade of Express™ Penta™ Putty Vinyl Polysiloxane Impression Material. In addition to an increase in the diameter, the tip of the catalyst cartridge cap now features plastic reinforcement (arrows). On the base cap two additional ribs have been included (arrows). This greatly increases the dimensional stability and further minimizes the risk of cap breakage.

- New: reinforced steel cartridge sheathed in plastic



Fig. 14: The new cartridge has steel inner tubes sheathed in plastic. Risk of breakage has been virtually eliminated. It is available in the standard shade – grey – and the lever in the product shade of Express™ Penta™ Putty.

PentaMatic™

The wish to ensure optimum handling for the Penta™ components resulted in the development of a self-opening mechanism, PentaMatic, which automatically makes the contents of the foil bags available for use as soon as the plunger discs exert pressure on the foil bags.

After starting up the Pentamix™ Mixing Unit, the pressure in the foil bag is increased so that the foil of the bag expands into the space provided for this purpose in the cartridge cap (Fig. 15). The spikes located in this area then pierce the expanded foil, causing it to burst in the entire space. This is heard as a clicking sound when the material is released.

Self-opening of the foil bag takes approx. 10 - 15 seconds with the Pentamix 2.

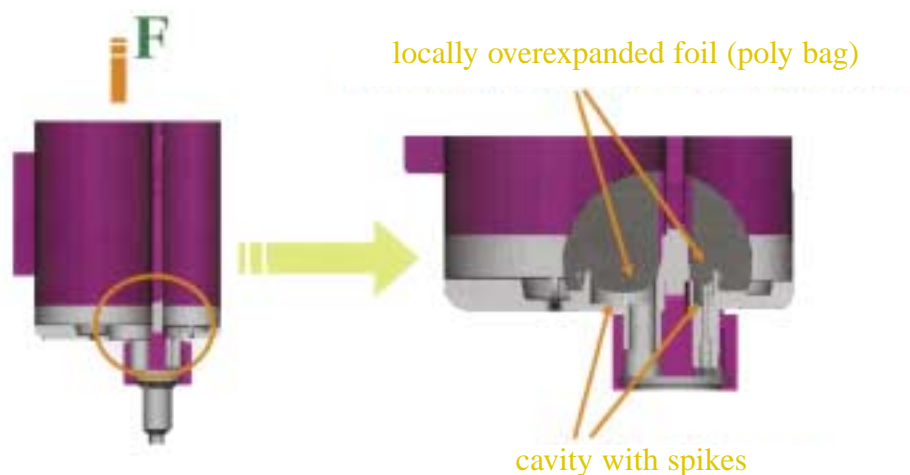

Fig. 15: Principle of PentaMatic™ self-opening mechanism for bags

Handling tailored to the needs of the dental office

Key handling benefits result when using the Pentamix 2 System.

Dynamic mixing provides precise results while at the same time eliminating typical handmix problems, thus obviously improving the impression quality (homogeneous and free of air voids). Mixing in the Pentamix 2 ensures reproducible results, simplifies the work procedure and represents a decisive step towards better hygiene at the dental office and cleanliness in the working area.

Composition

Product components

Express™ Penta™ Putty Vinyl Polysiloxane Impression Material is available in foil bags for the Pentamix™ 2. Other associated Pentamix System components are a reinforced metal Penta™ Cartridge and a special “red” Penta Mixing Tip (see Section New Pentamix System components, chap. Technical Overview).

Express™ Ultra-Light Body is supplied as a cartridge for the Garant™ 2 Dispenser.

Constituents

Qualitative composition of Express Penta Putty and Express Ultra-Light Body

Express™ Penta™ Putty

Vinyl Polysiloxane Impression Material

























Base	Catalyst
Silane treated quartz silica	Silicate fillers
Vinyl polydimethylsiloxane	Vinyl polydimethylsiloxane
White mineral oil	Platinum catalyst
Dimethyl methyl hydrogen polysiloxane	White mineral oil
Pigments (green)	

Express™ Ultra-Light Body

Vinyl Polysiloxane Impression Material

Base	Catalyst
Vinyl polydimethylsiloxane	Cristobalite
Cristobalite	Vinyl polydimethylsiloxane
Dimethyl methyl hydrogen polysiloxane	Silane treated silica
Silane treated silica	Poly(dimethylsiloxane)
Poly(methylsiloxane)	Platinum catalyst
Polyethylene glycol, siloxane terminated	

Comparison of Handmix/Automix Procedures

Procedures	Handmix-Procedure 1 Optosil™	Handmix-Procedure 2 Express™ STD Vinyl Polysiloxane Impression Material	Automix-Procedure Express™ Penta™ Putty Vinyl Polysiloxane Impression Material
Preparation			
Material required			
Dosing			
Dosing of putty base material			n/a
Dosing of putty catalyst			n/a
Dosed putty material (base and catalyst) on mixing pad			n/a
Mixing			
Taking up materials			n/a
Starting mixing of base and catalyst			n/a
Mixing (kneading)			n/a
Base and catalyst paste mixed			n/a
Filling the tray			
Preparation of Pentamix™ Unit – Attachment of new Penta™ Mixing Tip Red	n/a	n/a	
Even filling of impression tray by pressing button	n/a	n/a	
Rolling and subsequent insertion of mixed material into impression tray			n/a
Even distribution (n/a with Express™ Penta™ Putty) and shaping material in the impression tray with finger			Optional: 

3M ESPE Internal Application Test

Express™ Penta™ Putty and Express™ Ultra-Light Body Vinyl Polysiloxane Impression Materials underwent clinical testing in a two-month application test involving 31 dentists in Germany, France and Italy. Half the participants were putty hand-mix users and had no experience whatsoever of the Pentamix™ Mixing Unit. The remainder of the participants were already in possession of a Pentamix Mixing Unit, they were still using putty materials kneaded by hand for certain indications.

Most dentists utilize both the two-step putty wash and one-step putty wash technique, depending on the clinical indication. Only a small number exclusively use one of the two techniques. For the two-step putty wash technique the combination of Express Penta Putty / Express Ultra-Light Body was tested. For the one-step putty wash technique Express Penta Putty was combined with existing 3M ESPE wash materials. These were Express light body regular set, Imprint™ II light body regular set and Dimension™ Garant™ L.

A total of 517 precision impressions were taken by the dentists (260 with the two-step putty wash technique and 257 with the one-step putty wash technique).

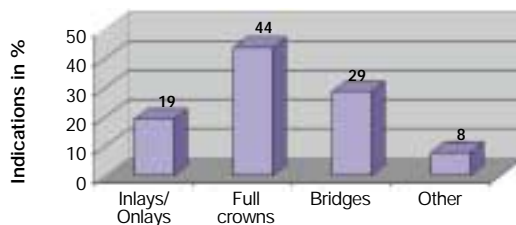

Fig. 16: Indications for which materials were used

The materials were mainly used for full crowns (44%), bridges (29%) and inlay/onlay restorations (19%). Implant, fixation and post impressions, overimpressions and veneer impressions were also made.

Express™ Penta™ Putty

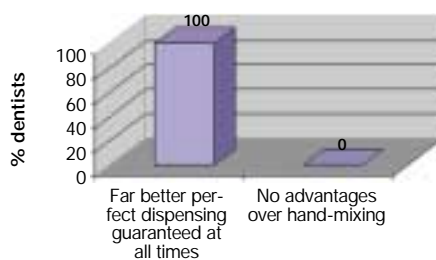

Fig. 17: Automatic dosing in the Pentamix™ compared with hand-mixing

The exact proportioning of the base and catalyst paste in the Pentamix Mixing Unit was seen by all dentists as a major benefit compared with hand-mixing. This provides a consistent material quality that can always be reproduced.

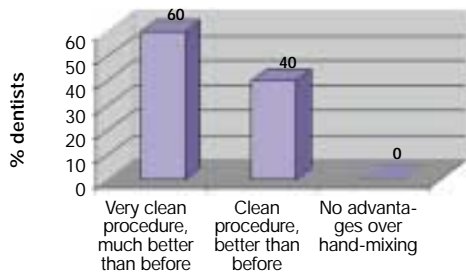

Fig. 18: Automatic mixing in the Pentamix™ 2 Mixing Unit compared with hand-mixing of a putty silicone

In the opinion of the dentists the automatic mixing of Express™ Penta™ Putty in the Pentamix™ 2 Mixing Unit represents a major benefit compared with hand-mixing as regards cleanliness of the procedure.

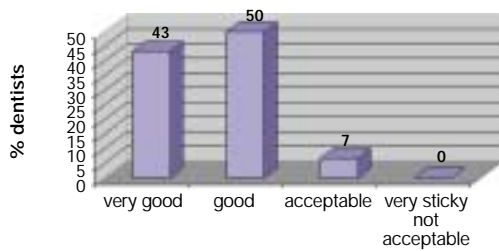

Fig. 19: Malleability of Express™ Penta™ Putty in the tray

One characteristic of putties is the possibility of evenly distributing the mixed material in the tray with the finger. Express Penta Putty also offers this typical characteristic – although it is only optional and not needed in this case. Automatic mixing in the Pentamix 2 assures a homogeneous filling of the tray so that it is no longer a necessary requirement to evenly distribute the material. 93% of the dentists rated Express Penta Putty as either very good or good as regards the malleability of the mixed material in the tray.

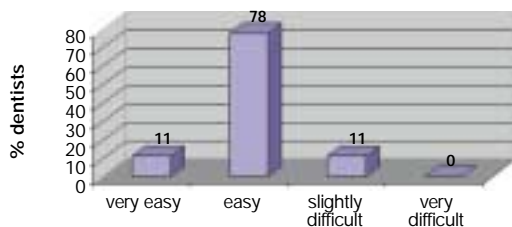

Fig. 20: Carving of first impressions with Express™ Penta™ Putty

For the two-step putty wash technique it is important that the first impressions can be carved easily. This requirement is also very well satisfied by Express Penta Putty Impression Material. 89% of the dentists expressed the view that carving of Express Penta Putty is very easy to easy.

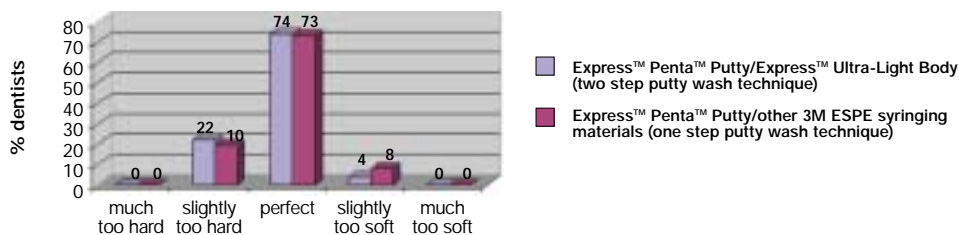

Fig. 21: Final rigidity of Express™ Penta™ Putty

The results of the application test show that the final rigidity of Express Penta Putty not only satisfies the requirements of the two-step putty wash technique, but also those of the one-step putty wash technique. 74% of the dentists rated the final rigidity for both techniques as perfect.

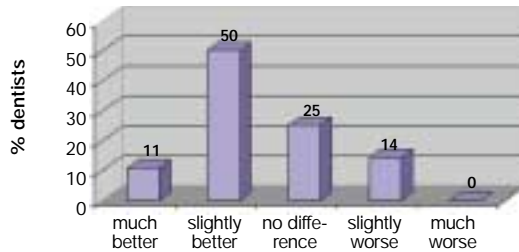

Fig. 22: Comparison of working properties between Express™ Penta™ Putty and putty materials currently in use

61% of the dentists considered Express™ Penta™ Putty Vinyl Polysiloxane Impression Material to be better than their current putty material, and another 25% rated it as comparably good. As the main advantages over their current materials they cited in particular the benefits of the Pentamix™ 2 Mixing Unit, i.e.:

- precise dosing
- homogeneous mixing
- and the clean and simple handling with a putty material

Express™ Ultra-Light Body Vinyl Polysiloxane Impression Material

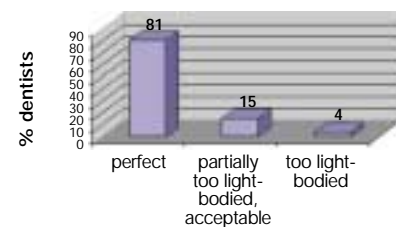
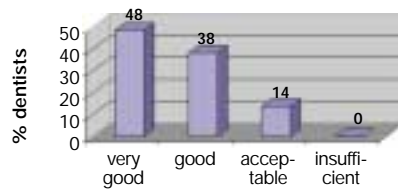

Fig. 23a: Ability of Express™ Ultra-Light Body to stay at tooth upon syringing
 Fig. 23b: Layer thickness of Express™ Ultra-Light Body in first impressions

For the two-step putty wash technique it is essential that the wash material is structurally viscous. The material must stay at the prepared tooth upon syringing without dripping as well as flow in extremely thin layers in the second impressions when pressure is applied. The clinical results show that Express™ Ultra-Light Body offers these characteristics.

86% of the dentists rate the ability of Express Ultra-Light Body to stay at the tooth and/or at the preparation upon syringing as very good to good. 80% consider the layer thickness in second impressions to be perfect. 61% also believe that the layer thicknesses with Express Ultra-Light Body are even thinner than with the materials currently in use.

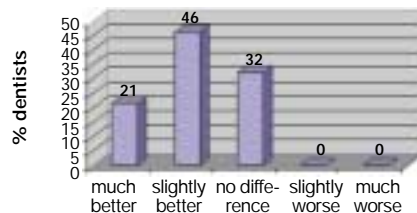

Fig. 23c: Flow properties of Express™ Ultra-Light Body compared with the wash materials currently in use

In comparison with the wash materials currently in use, the flow properties of Express Ultra-Light Body were rated as better by 68% of the dentists.

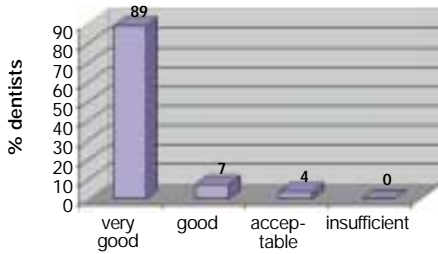

Fig. 24: Detail reproduction by Express™ Ultra-Light Body Vinyl Polysiloxane Impression Material

Express™ Ultra-Light Body Vinyl Polysiloxane Impression Material is characterized by very high detail reproduction of the impressions. It was rated as very good by 89% of the dentists.

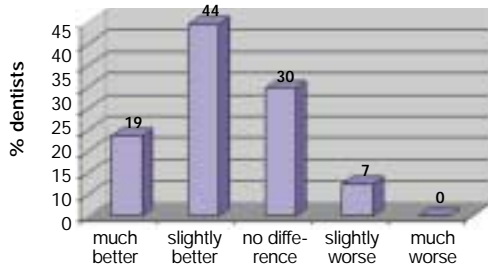

Fig. 25: Overall properties of Express™ Ultra-Light Body compared with current wash materials

63% of the dentists thought Express Ultra-Light Body was better than their current wash material, and another 30% rated it as comparably good. As the main advantages over their current materials they cited the following:

- the improved flow properties
- the very thin flow under pressure combined with the absence of dripping of the material upon syringing
- the very good level of detail reproduction

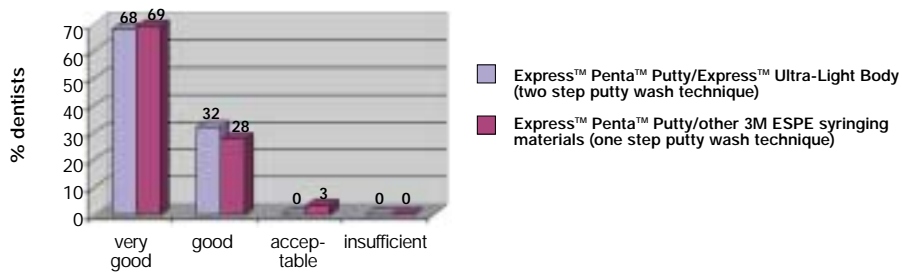

Fig. 26: Accuracy of fit of the prosthetic work

Not only the two-step putty wash technique using Express™ Penta™ Putty and Express™ Ultra-Light Body Vinyl Polysiloxane Impression Materials but also the one-step putty wash technique with Express Penta Putty and various 3M ESPE syringing materials (Express Light Body regular set, Imprint™ II Light Body regular set and Dimension™ Garant™ L Vinyl Polysiloxane Impression Materials) provided brilliant results with respect to the fit of the prosthetic work.

As regards the two-step putty wash technique 68% of the dentists taking part in the test considered the fit to be very good, and another 32% rated it as good. The results for the one-step putty wash technique are virtually identical.

Typical effects of the two-step putty wash technique, e.g. crowns that are too tight due to displacement of the tray material when applying the wash material were not observed. This once again underlines how well the tray and wash material are adapted to each other in the combination of Express Penta Putty and Express Ultra-Light Body.

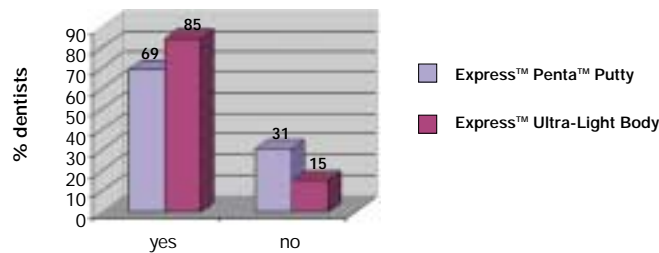

Fig. 27: Substitution of current products for Express™ Penta™ Putty / Express™ Ultra-Light Body Impression Material?

The dentists could see for themselves in the clinical application the advantages of both Express Penta Putty and Express Ultra-Light Body. 69% would substitute their current putty material for Express Penta Putty, and as many as 85% would substitute their current wash material for Express Ultra-Light Body.

The following were cited as the main advantages:

- The perfect combination of Express Penta Putty and Express Ultra-Light Body for the two-step putty wash technique
- The clean and simple handling with a putty material
- The extraordinary flow properties of Express Ultra-Light Body
- The very high level of detail reproduction of the impressions
- The very good fit of the prosthetic works

Instructions for Use

Product Description

Express™ Penta™ Putty Vinyl Polysiloxane Impression Material is a silicone addition polymerization material of putty consistency (ISO 4823 Type 0). The material is mixed in the Pentamix™ 2 Mixing Device; the mixing ratio is 5 volumes base paste : 1 volume catalyst. The poly bags are sealed with a PentaMatic™ sealing cap. This PentaMatic sealing cap automatically opens the poly bag in the Pentamix 2 Mixing Unit, as soon as sufficient pressure has been created by the plunger.

Express™ Ultra-Light Body is a hydrophilic silicone addition polymerization material of light-bodied consistency (ISO 4823 Type 3) in the Garant™ Cartridge. Mixing ratio is 1 volume base paste : 1 volume catalyst.

All products mentioned are manufactured by 3M ESPE.

⇒ For details on all products mentioned, please refer to the corresponding Instructions for Use. Instructions for Use should not be discarded for the duration of product use.

Areas of Application

⇒ All precision impressions (e.g. of crown, bridge, inlay, and onlay preparations)

Preparation

Impression Trays:

Particularly suitable are rigid unperforated and perforated metal trays.

- For sufficient adhesion, apply a thin layer of VPS Tray Adhesive, manufactured by 3M ESPE, on the tray and allow it to dry completely (min. 5 minutes - test with a finger, ideal drying time: 15 minutes).

Penta™ Cartridge/Poly Bag:

- Only fill Express Penta Putty bag into the designated metal-reinforced Express Penta Putty Cartridge.
- Express Penta Putty poly bags may only be used together with special Penta mixing tips “red”.
- If a new mixing tip has already been installed when the Penta Cartridge is inserted, check prior to mixing whether the drive shaft of the Pentamix 2 Mixing Unit engages the mixing tip.
- Prepare new poly bags by discarding approx. 3 cm of a strand prior to first impression taking. The paste must be extruded in a uniform color.

Garant™ Dispenser/Cartridge:

- Place the Express Ultra-Light Body Impression Material in the Garant dispenser, and check shortly before application to ensure that both Garant Cartridge openings are not clogged.
- With Garant Cartridges that have not been previously used, extrude a small amount of paste until the base and catalyst paste flow out evenly. Subsequently, attach a new Garant mixing tip yellow.

- For direct application in the mouth, attach a Garant™ Intraoral Tip yellow onto the mixing tip. If needed, the exit opening for the intraoral tip can be enlarged with a scalpel.
 - If the paste is not directly applied using the Garant dispenser, a separate elastomer syringe can be filled directly from the Garant mixing tip (without an intraoral tip).
- Material that has set inside the Garant mixing tip should not be extruded by force as this may damage the Garant Cartridge and Garant mixing tip and result in the formation of leaks.

Retraction

Suitable retraction agents include aluminum hydroxide chloride or aluminum sulfate solutions.

- Keep the area dry from which an impression is to be taken.
- Hemostatic threads or rings may be used for subgingival preparations.
- Thoroughly remove the residue of the retraction agent by rinsing and drying before taking the impression.

Dosing and Mixing

Express™ Penta™ Putty Vinyl Polysiloxane Impression Material is automatically dosed and mixed in the Pentamix™ 2 Mixing Unit.

Express™ Ultra-Light Body is dosed and statically mixed in the Garant dispenser.

Times

	Processing time from start of mixing* min:sec	Residence time in mouth min:sec
Express™ Penta™ Putty	1:30	2:30
Express™ Ultra-Light Body	1:30	2:30

These are the processing times at 23°C/74°F. Higher temperatures shorten, and lower temperatures prolong the overall processing time.

* Start of mixing = Entry of paste into the Penta™ or Garant™ mixing tip

Impression Taking

Two-Step Impressions:

- At the start of mixing of Express Penta Putty, be sure to observe the entry of the paste into the mixing tip, and ensure that base paste and catalyst paste flow into the mixing tip. The mixed paste must be an even light green.
- Load the impression tray prepared with adhesive with Express Penta Putty, keeping the mixing tip constantly immersed in the paste to avoid air bubble formation.
- Then, position the impression tray in the mouth.
- After the preliminary impression has set, remove it from the mouth and thoroughly clean and dry.
- Trim out any undercuts and interdental septa, etc., and cut spillways.
- Place Express Ultra-Light Body in the appropriate locations in the preliminary impression. If needed, apply material around the prepared teeth, keeping the mixing tip constantly immersed in the paste to avoid air bubble formation.
- Replace the preliminary impression in the mouth.
- After the residence time in the mouth, remove the impression from the mouth.

One-Step Technique

Use the hand-wheel to turn the plungers of the Pentamix 2 Mixing Unit downward until resistance is noticed.

- At the start of mixing of Express™ Penta™ Putty Vinyl Polysiloxane Impression Material, be sure to observe the entry of the paste into the mixing tip, and ensure that base paste and catalyst paste flow into the mixing tip. The mixed paste must be an even light green.
- Load the impression tray prepared with adhesive with Express Penta Putty, keeping the mixing tip constantly immersed in the paste to avoid air bubble formation.
- While the assistant is loading the tray, the dentist may apply the material around the dried preparation from the bottom up. Depending on the number of cavities, initiate application such that tray loading and application of material around the preparation are completed at the same time.
 - Suitable materials for applying around the preparation are light-bodied silicone addition polymerization materials from the Imprint™, Express™ or Dimension™ product lines, all manufactured by 3M ESPE.
- Slowly place the loaded tray in the mouth parallel to the long axes of the prepared teeth, and hold the tray in position without applying pressure.
- Remove the impression from the mouth, once the residence time in the mouth has elapsed.

After Impression Taking

- Thoroughly examine and explore the sulcus of the prepared teeth and surrounding dentition. Remove any residual cured impression material from the mouth.

Hygiene

- Place the impression in a standard disinfectant solution, e.g. Impresept™*, manufactured for 3M ESPE, for the period of time recommended by the manufacturer, i.e. 10 min in the case of Impresept. Excessive disinfection may damage the impression.
- After disinfection, rinse the impression under running water for approx. 15 seconds.

* Impresept is not available in all countries.

Model Preparation

- In order to obtain a bubble-free model, rinse the impression briefly and dry before pouring, or use a silicone surfactant.
- Prepare a cast from the impression using a commercial specialized stone plaster no earlier than 2 hours after impression taking. There are no other time limitations.

Cleaning

- Garant™ Dispenser: Remove paste that has not set using an alcohol-soaked cloth. The dispenser handle and plunger can be autoclaved up to a temperature of 135° C/275° F. Disassemble the dispenser before autoclaving. Glutaraldehyde-based solutions can be used for disinfection.
- Impression Tray: The adhesive can be removed from impression trays using acetone.

Notes

The oxygen inhibition layer of composite materials, e.g. in fillings or core buildups, may impair the setting of silicone impression materials, and should therefore be removed completely.

- Keep the filled Penta or Garant mixing tip on top of the cartridge to serve as a closure until the next use. Removing and replacing the spent Penta or Garant mixing tip may lead to carry-over of paste and ensuing formation of clogs.
- Vinyl polysiloxane impression materials must not be combined with condensation polymerization silicones or polyether impression materials. Even trace amounts impair the setting process.

- Disposable latex gloves impair the setting of silicone impression materials. Vinyl gloves are more suitable.
- In no case should the impressions come into contact with solvent-containing liquids, as this may result in swelling and imprecise modelling.

Incompatibilities

In susceptible individuals, sensitization to the product can not be excluded. If allergic reactions are observed, discontinue the use and remove the product completely.

Technical Data

The impression materials comply with ISO 4823 type 0 putty consistency or type 3 light-bodied consistency.

	Express™ Penta™ Putty Vinyl Polysiloxane Impression Material	Express™ Ultra-Light Body Vinyl Polysiloxane Impression Material
Strain in compression:	1,8%	3,8%
Recovery from deformation:	99,5%	99,7%
Linear dimensional change (after 24 h):	-0,2%	-0,4%

Storage and Stability

Store the product at 15-25° C/59-77° F.

Do not use after the expiration date.

Store impressions at temperatures below 30° C/86° F.

Customer Information

No person is authorized to provide any information which deviates from the information provided in this instruction sheet.

Warranty

3M ESPE warrants this product will be free from defects in material and manufacture.

3M ESPE MAKES NO OTHER WARRANTIES INCLUDING ANY IMPLIED WARRANTY OF MERCHANTABILITY OR FITNESS FOR A PARTICULAR PURPOSE. User is responsible for determining the suitability of the product for user's application. If this product is defective within the warranty period, your exclusive remedy and 3M ESPE's sole obligation shall be repair or replacement of the 3M ESPE product.

Limitation of Liability

Except where prohibited by law, 3M ESPE will not be liable for any loss or damage arising from this product, whether direct, indirect, special, incidental or consequential, regardless of the theory asserted, including warranty, contract, negligence or strict liability.

Express™ Penta™ Putty – Step-by-Step

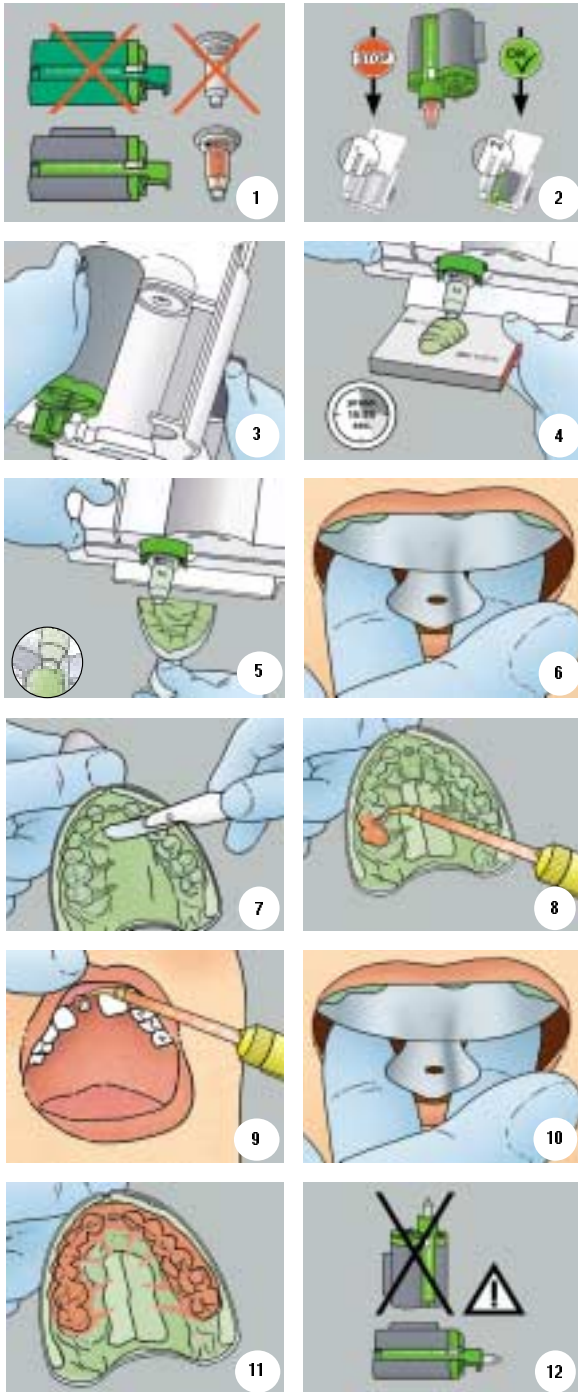

Frequently Asked Questions (FAQ's)

1. Can Express™ Penta™ Putty foil bags also be used with plastic Penta Cartridges?

The answer to this is “No”.

Due to the high viscosity of the paste (this is a putty material after all), greater forces are exerted on the cartridges when conveying Express Penta Putty Impression Material compared with other 3M ESPE Penta Impression Materials. Plastic Penta Cartridges may expand slightly to the side when exposed to such great pressure, possibly causing the foil bag to become jammed between the cartridge and plunger. This would make it difficult or impossible to turn back the plunger or adjustment knob. Equally it might only be possible to convey the jammed paste too slowly or not at all, resulting in poor mixing quality. In the long term the plastic cartridges would not withstand the high stresses and would then break.

The new Penta Cartridges are now far more stable thanks to their inner tubes made of steel. There is no longer any lateral expansion during the conveying of material, thus preventing the effects described above as well as the breakage of cartridges.

2. Why does Express Penta Putty become warm during mixing in the Pentamix™ 2 Mixing Unit?

The reason for the paste becoming warm is the high viscosity of the base paste. When the highly viscous paste passes through the Penta Mixing Tip red, very high shear forces are produced. Part of this energy is transferred to the paste itself, resulting in a temperature increase of approx. 7 °C in the course of mixing. Patients find warming of the paste very pleasant. Depending on the room temperature the paste is warmed up to 30-35 °C by the time the tray is inserted into the mouth.

The warming of the paste during mixing has no influence on the working time of 1:30 min specified for Express Penta Putty in the instructions for use as the increase in temperature has already been taken into account.

Important: The tray should be filled with Express Penta Putty in a single operation without setting it down. If the unit is briefly stopped when filling the tray (e.g. to turn round the tray), there may be a sharp increase in the temperature of the paste in the Penta mixing tip red when it is started up again. The result may be a far shorter working time for the impression material.

3. How suitable is Express Penta Putty Impression Material for the one-step tray wash technique and which LB materials can be used?

Although Express Penta Putty has been specially developed for the two-step putty wash technique together with Express Ultra-Light Body, it is also highly suitable for the one-step putty wash technique.

However, not all syringing materials based on VPS are equally appropriate for combination with Express Penta Putty since parameters such as structural viscosity, consistency, flowability etc. also play a key role in the quality of an impression using the one-step putty wash technique. We recommend 3M ESPE products such as Express LB regular and fast set, Imprint™ LB regular and fast set, and Dimension™ Garant™ L or Dimension™ Garant™ L Quick Vinyl Polysiloxane Impression Materials. When using these combinations of products it should be ensured that the intraoral setting time specified for each syringing material in the instructions for use is strictly observed. The time of removal from the mouth then depends on the setting time of the slower of the two materials.

Express Penta Putty is not compatible with C-silicones, alginates, polyethers and hydrocolloids.

4. Carving of first impression:

The carving of first impressions is a very time-consuming step in the two-step putty wash technique that is nevertheless essential if satisfactory impression results are to be obtained. With Express™ Ultra-Light Body Vinyl Polysiloxane Impression Material this step can now be made easier, thus saving valuable time for both dentist and patient.

Due to its outstanding characteristics in terms of structural viscosity, demonstrated clinically in no dripping from the tooth combined with high flowability under pressure, in conjunction with its ultra light-bodied consistency, Express Ultra-Light Body flows in extremely thin layers in second impressions. This property means that carving of the first impression is less intensive in comparison with standard wash materials.

Excellent impression results can be obtained if the areas likely to shear off on repositioning are removed in the first impression, e.g. undercuts and interdental septa. Discharge channels for the syringing material should also be created (see Fig. 28).



Fig. 28: Carved first impression with Express™ Penta™ Putty Impression Material

In larger cases, where intraoral syringing is limited by the working time, even the following technique can be used: It is sufficient to place the material in the cut first impression as shown in Fig. 29. A thin strand along the preparation margins is adequate.



Fig. 29: Express™ Ultra-Light Body placed in the cut first impression

The perfect combination of a high level of hardness with Express™ Penta™ Putty in conjunction with the extremely thin layer thicknesses of Express Ultra-Light Body in the second impressions greatly reduces the well-known displacement effects which occur with the two-step putty wash technique. Displacement of the tray material when wash material is applied and return in the original shape, resulting in too small restorations is not a problem any longer. This ensures the high precision of the restorations.

5. What is the cause of smeary impression surfaces in the preparation area?

Such effects are often not seen until casting and are due to the adhesion of plaster to the impression or the adhesion of impression material to the plaster cast. The following causes are possible:

Cause	Solution
❖ Placement of a composite restoration or composite core build-up materials just performed	❖ Finish, clean, isolate restoration or core build-up materials
❖ Temporary restoration produced directly before impression	❖ Clean row of teeth with solvents, e.g. orange oil, ethanol and cotton swab
❖ All traces of retraction solutions not removed	❖ Carefully remove retraction solution using water spray
❖ Use of Latex gloves	❖ Check Latex gloves for tolerance, if necessary change brand
❖ Use of surface anaesthetic containing adrenaline	❖ Ask patient to rinse out well
❖ Contact with C-silicones, e.g. when blocking off	❖ Use VPS or light-cured plastic for blocking off

6. Does the working time of the materials depend on the temperature?

Like all VPS the working times of Express™ Penta™ Putty and Express™ Ultra-Light Body Vinyl Polysiloxane Impression Material depend on the temperature.

With temperatures over 25 °C at the dental office there is a clear reduction in the working time of Express Penta Putty (1:30 min at 23 °C). In cases where a large number of prepared teeth are to be syringed, e.g. extensive prosthetic work, the working time of Express Penta Putty may then be too short, particularly when using the one-step putty wash technique.

On such hot days we recommend storing the Express Penta Putty foil bags in the metal cartridges in the refrigerator at 8 °C-10 °C and placing them in the warm consulting room approx. 60 minutes before taking impressions. We strongly advise against mixing the paste in the Pentamix™ 2 Mixing Unit directly after removal from the refrigerator without warming it up beforehand as the viscosity of the paste increases at low temperatures (<18 °C). The result would be much greater dispensing forces during conveying of the cool paste, causing heavy wear on the Pentamix Mixing Unit.

7. What reasons are there for poor bonding of the wash material to the tray material?

Cause	Solution
❖ Classes of materials not compatible	❖ Do not combine Express™ Penta™ Putty and Express™ Ultra-Light Body impression materials with C-silicones, alginates, hydrocolloids or polyethers
❖ Preliminary impression is contaminated (by saliva etc.)	❖ Carefully rinse, clean and dry preliminary impression
❖ Temporary restoration was produced directly before impression or precision impression was also used as temporary work key	❖ Only produce temporary restoration after precision impression or create separate temporary work key

8. How can the formation of voids in the plaster cast be avoided?

The most common causes for the formation of voids in the plaster cast are:

- casting the impression too early and
- excessive surface tension of the impression

Voids will form if casting is carried out too early. This is due to the release of hydrogen from the polymerization reaction of the molecules into the surface of the plaster. This chemical reaction is completed two hours after impression-taking. The formation of voids due to the development of hydrogen during casting will then no longer occur.

The surface tension of the impression can be reduced by the use of silicone wetting agents applied shortly before casting.

9. Pentamix™ 2 Mixing Unit

Tips and Tricks for Pentamix first time users

a) General questions on the Pentamix 2 Mixing Unit

Pentamix™ 2 Mixing Unit What to do when...	Causes	Solutions
Unit does not start	Plunger is in bottom position	Turn adjustment knob to plunger from this position
Paste not dispensed	1. Cartridge is empty 2. Foil bag openings glued up with contamination material 3. Plunger is jammed	1. Insert new foil bags 2. Clean foil bag openings 3. Check that handwheel moves freely
Unit does not switch off	Start button is jammed	Press start button again, if necessary remove mains plug and release start button
Paste flows too slowly or not at all	Paste temperature too low	Bring up to room temperature, min. 18°C
Cartridge cannot be inserted in unit	1. Plungers not in top position 2. Cartridge locking lever not closed	1. Move up plungers by turning handwheel clockwise as far as it will go and hold. 2. Close cartridge locking lever
Material initially conveyed not homogeneous in color	There has been a minimal change in the length of the foil bags through the cartridges being stored vertically outside the unit.	1. Store cartridges horizontally 2. Always check mixing quality for a uniform shade, typical of paste

b) Questions related only to Express™ Penta™ Putty Vinyl Polysiloxane Impression Materials

Pentamix™ 2 Mixing Unit: What to do when:	Causes	Solutions
Penta™ Mixing Tip red gets warm /the working time of the impression material is shortened	<ol style="list-style-type: none">1. A new foil bag was opened.2. The plunger was not in contact with the foil3. The Pentamix Mixing Unit's activation button was released while loading the	<ol style="list-style-type: none">1. Don't release the Pentamix 2 Mixing Unit's activation button after paste is dispensed in a uniform color, but immediately load tray.2. Before pressing the Pentamix 2 Mixing Unit's activation button turn down handwheel until plunger is in contact with foil bag3. Load the tray in a single operation without releasing the Pentamix 2 Mixing Unit's tray activation button

Clinical Case Study Documentation

Clinical Case Report by Dr. Gunnar Reich, Munich, Germany: Lava™ all-ceramic bridge 14-16

The patient came to our dental office asking for the gap in the first quadrant (tooth 15) to be corrected. For this patient the most important aspects of a prosthetic restoration were high strength, aesthetics and freedom from metal. A single-tooth implant was out of the question for the patient. We catered for these requirements with an all-ceramic restoration with zirconium oxide ceramic (3M ESPE Lava).



Fig. 1: Initial situation gap 15 for bridge 14 - 16 vestibular view



Fig. 2: Impression with Position™ Penta™ and Position™ Tray for fabrication of a temporary restoration



Fig. 3/4: Teeth 14 and 16, prepared (buccal/occlusal view)



Fig. 5: Preparation 14 with retraction cord, placed (buccal view)

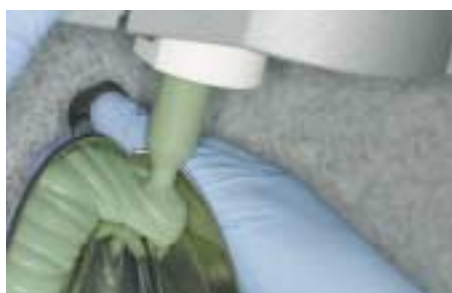

Fig. 6: Automatic filling of the impression tray with Express™ Penta™ Putty Vinyl Polysiloxane Impression Material



Fig. 7: First impression with Express™ Penta™ Putty (before being carved)



Fig. 8: Carved first impression with Express™ Penta™ Putty. The vestibular and palatal ridge and septa were removed where these interfered with the impression. Sharp edges were smoothed. Discharge channels were only created where the distance between the preparation margin and the cut free vestibule or palatum was more than 1 cm. The preparation itself was not touched while doing so.



Fig. 9/10: Application of Express™ Ultra Light-Body Vinyl Polysiloxane Impression Material in the first impression. A thin strand was applied over the entire occlusal surface, and another strand along the preparation margins.



Fig. 11: Intraoral application of Express™ Ultra-Light Body



Fig. 12/13: Final impression with two-step putty wash technique involving teeth 14 and 16 with Express™ Penta™ Putty / Express™ Ultra Light Body



Fig. 14/15: Final bridge on the master model



Fig. 16: Fit check with Express™ Ultra Light Body



Fig. 17/18: Cemented bridge with the self-adhesive universal resin cement RelyX™ Unicem by 3M ESPE (occlusal/vestibular view)



Fig. 19: Final picture

Clinical photos by Dr. Peter Chlum, Ebersdorf, Germany

Clinical case – Upper jaw bridge 13 to 16, lower jaw bridge 34-35 with attached bridge unit 36

The patient came to our dental office asking for the gap in the right upper jaw to be corrected and the left lower teeth to be extended (Fig. 1 and 2). After preparation of the teeth and the placement of the retraction cords (double-cord technique) (Fig. 3 and 4), the one-step tray wash technique was used with Express™ Penta™ Putty / Express™ Ultra Light Vinyl Polysiloxane Impression Materials on the upper jaw (Fig. 5 to 7) and Express Penta Putty / Imprint™ II Impression Materials on the lower jaw (Fig. 8 and 9). Finally we restored the teeth with temporary Protemp™ 3 Garant™ Composite crowns produced chairside (Fig. 10 and 11). After completion of the bridges these were permanently cemented using RelyX™ Unicem Self-Adhesive Universal Resin Cement (Fig. 12 and 13).



Fig. 1 Initial situation teeth 13 and 16 (occlusal/vestibular view)



Fig. 2 Initial situation teeth 34 and 35



Fig. 3 Preparation upper jaw occ. view



Fig. 4 Preparation lower jaw occ. view



Fig. 5 One-step putty wash technique on upper jaw with Express™ Penta™ Putty / Express™ Ultra-Light Vinyl Polysiloxane Impression Materials



Fig. 6 Close-up: one-step putty wash technique on upper with Express™ Penta™ Putty / Express™ Ultra-Light tooth 13



Fig. 7 Close-up: one-step putty wash technique on upper jaw with Express™ Penta™ Putty / Express™ Ultra-Light Vinyl Polysiloxane Impression Materials tooth 16



Fig. 8 One-step putty wash technique on lower jaw with Express™ Penta™ Putty / Imprint™ II teeth 34, 35



Fig. 9 Close-up: one-step putty wash technique on lower jaw with Express™ Penta™ Putty / Imprint™ II teeth 34, 35



Fig. 10 Temporary crowns, upper jaw



Fig. 11 Temporary crowns, lower jaw



Fig. 12 Upper jaw bridge after removal of residual cement - permanently cemented with RelyX™ Unicem Self-Adhesive Universal Resin Cement



Fig. 13 Lower jaw bridge after removal of residual cement - permanently cemented with RelyX™ Unicem Self-Adhesive Universal Resin Cement

Summary

Express™ Penta™ Putty and Express™ Ultra-Light Body Vinyl Polysiloxane Impression Materials are two innovative impression materials for the two-step putty wash technique which have been optimally adapted to each other. They guarantee the dentist maximum precision when taking impressions and at the same time offer all the convenience of modern technology.

Express Penta Putty is the first 3M ESPE VPS with a real “putty” consistency for automatic mixing in the Pentamix™ 2 Mixing Unit. It features the characteristics appreciated in a putty material as well as offering the benefits of the Pentamix System such as a consistently reproducible mixing quality that can always be reproduced, in addition to simple and clean handling.

Express Ultra-Light Body is a very light-bodied VPS material supplied in the Garant™ Cartridge that has been specially developed for use in combination with Express Penta Putty in the two-step putty wash technique. It is characterized by excellent flow properties, a high structural viscosity and hydrophilicity. In addition, it offers a high tear strength thanks to new high crosslinking monomers with good curing properties.

Bibliography

Anusavice K. J.,

Philips' Science of Dental Materials, 10th Edition, W. B. Saunders, Philadelphia, 1996.

Meiners H., Lehmann K. M.,

Klinische Materialkunde für Zahnärzte, Carl Hanser Verlag, München Wien, 1998.

Peutzfeldt A., Asmussen E.,

Effect of disinfecting solutions on accuracy of alginate and elastomeric impressions, Scand J Dent Res 97, 470-475, 1989.

Meiners H., Rohring R.,

Kompatibilität des Desinfektionsmittels Impresept mit Abformmassen, Dental-Labor, XXXVI-II, Heft 9, 1223-1224, 1990.

Espe Dental AG (Hrsg.),

Die Präzisionsabformung – ein Leitfaden für Theorie und Praxis, 62, 1999.

Langenwalter E. M., Aquilino S. A., Turner K. A.,

The dimensional stability of elastomeric impression materials following disinfection, J Prosth Dent 63, 270-276, 1990.

Wirz J., Jäger K., Schmidli F.,

Abformung in der zahnärztlichen Praxis, G. Fischer Verlag, Stuttgart, 1993.

Wöstmann B.,

Zum derzeitigen Stand der Abformung in der Zahnheilkunde, Habilitationsschrift, Münster 1992.

Millon B.,

An update on elastomeric impression materials, Dental News, Vol II No. II, p.17, 1995.

Johnson G. H.,

Impression materials. In: Graig R. G., Powers J. M.: Restorative Dental Materials, 11th Edition, Mosby, Inc. St. Louis, Missouri, 329-391, 2002

Luthardt R. G.,

Eine quantitative und qualitative Analyse der 3D-Genauigkeit zahnärztlicher Abformungen, Habilitationsschrift, TU Dresden, 2002

Nissan J., Laufer B.-Z., Brosh T., Assif D.,

Accuracy of three polyvinyl siloxane putty-wash impression techniques, J Prosthet Dent 83, 161-165, 2000.

Wagner I., Gramann J., Richter B., Zech J., Fetz J.,

Insertion forces of conventional and new automixed putty impression materials, Abstract submitted for the Joint Meeting of the Continental European, Israeli, and Scandinavian Divisions of the IADR (August 25 – 28, 2004, Istanbul).

Zech J., Richter B.,

Tensile strength and contact angle of VPS impression materials, Abstract submitted for the Joint Meeting of the Continental European, Israeli, and Scandinavian Divisions of the IADR (August 25 – 28, 2004, Istanbul).

ISO 4823 Dental elastomeric impression materials, 1992/2000

DIN 53505 hardness tests according to Shore A, C and D.

Technical Data

Physical-technical data

Property	Limit	Express™ Penta™ Putty Vinyl Polysiloxane Impression Material	Express™ Ultra-Light Body Vinyl Polysiloxane Impression Material
----------	-------	--	--

ISO 4823-00

Consistency (mm)	Type 0: ≤35	31-35	
Disc diameter (mm)	Type 0: ≥36		44-50
Total working time* (min:sec)		01:30:00**	01:30
Strain in comparison (%)	Type 0: 0.8-20	1.5-3.0	
	Type 3: 2-20		3.0-5.0
Recovery after deformation (%)	>96.5	>99.4	>99.5
Linear dimensional change (%)	<1.5	-0.2 to 0.4	-0.2 to 0.4
Compatibility with gypsum Typ 3, 4, 5 (mm)	Type 0: 0.075	pass	
	Type 3: 0.050		pass
Detail reproduction (mm) (Visibility of lines)	Type 0: 0.075	pass	
	Type 3: 0.020		pass

DIN 53505

Shore A			
after 15 min		65-78	50-55
after 1 hour		70-78	50-55
after 24 hours		70-80	54-59
Flow properties*** (mm)		≥2,0	≥17

* = The data from the ISO test for the total working time may differ from the actual working time at the dental office, thus explaining possible differences in the instructions for use

** Measured according to ISO 4823-00 (1992)

***= Penetration of impression material in a wedge-shaped gap under pressure. Depending on the flowability this results in a test specimen shaped like a shark fin; its height is then measured.

Times

	Working time from start of mixing*	Intraoral setting time
Express™ Penta™ Putty Impression Material	01:30	02:30
Express™ Ultra-Light Body Impression Material	01:30	02:30

The working times apply at 23 °C/74 °F. The total working time is shortened by higher temperatures and lengthened by lower temperatures.

*= Start of mixing = introduction of paste into Penta or Garant™ mixing tip



The charts in this Technical Product Profile were reproduced by 3M ESPE from data listed in the cited sources.

3M, ESPE, Dimension, Express, Garant, Impregum, Impresept, Imprint, Ketac, Lava, Penta, PentaMatic, Pentamix, Position and Protemp are trademarks of 3M or 3M ESPE AG.

Aquasil is a trademark of Dentsply/Caulk. Mixpac is a trademark of ConPro Tec Inc. Optosil, Provil and Xantopren are trademarks of Heraeus Kulzer. Panasil is a trademark of Kettenbach GmbH. President is a trademark of Coltene-Whaledent.

3M ESPE

3M ESPE AG · ESPE Platz
D-82229 Seefeld
E-mail: info3mespe@mmm.com
Internet: <http://www.3mespe.com>

Dental Products

3M Center
Building 275-2SE-03
St. Paul, MN 55144-1000
USA

© 3M 2004

70200954553/01(10.2004)